

REVISIONS						
REV	ECO NO.	DESCRIPTION	BY	DATE	APP'D BY	DATE
2		REDRAWN	AAM	10/22/1999	RRR	10/22/1999
3	23612	UPDATED AND ADDED GAGE	TonyD	11/29/2014		
4	24190	"(NOT SUPPLIED WITH TOOL)" ADDED TO GAGE	DonnaM / TonyD	3/3/2016		

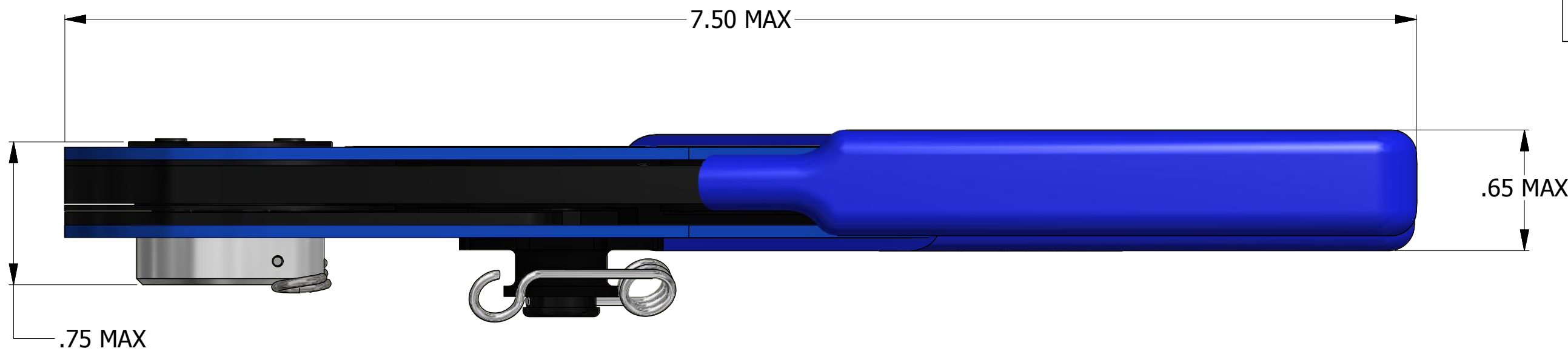

GAGING LIMITS OF INDENTERS		
SEL NO	INSPECTION GAGE	
	Ø GO ±.0001	Ø NO-GO ±.0001
1	.0130	.0180
2	.0160	.0210
3	.0190	.0240
4	.0220	.0270
5	.0260	.0310
6	.0300	.0350
7	.0340	.0390
8	.0390	.0440

CHECK WITH GAGE: G125 SEL #8

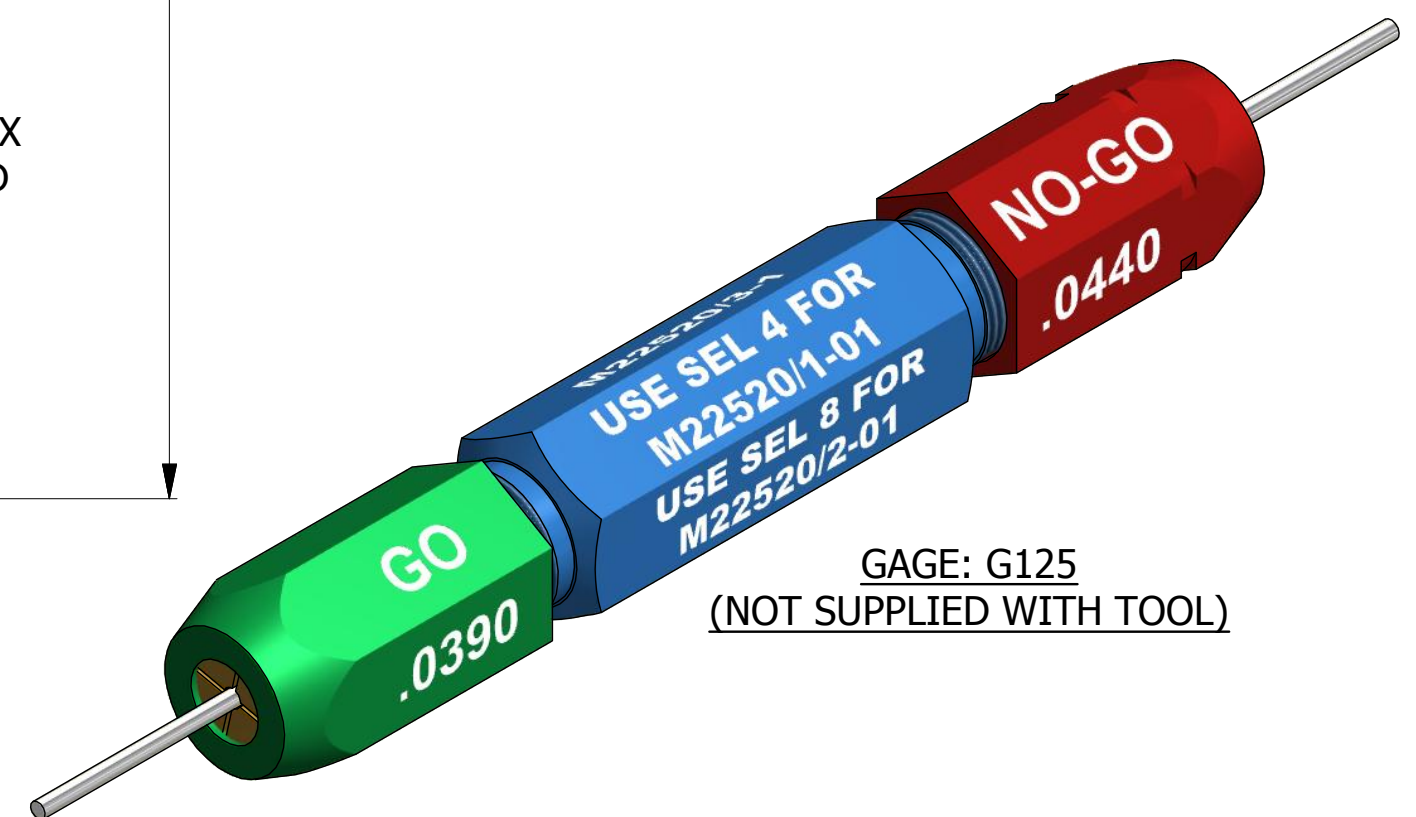

**UNCONTROLLED DOCUMENT  
WILL NOT BE UPDATED**  
DIMENSIONS IN INCHES - UNLESS OTHERWISE SPECIFIED

RESTRICTED & CONFIDENTIAL  
CONFIDENTIAL PROPERTY OF DANIELS MANUFACTURING CORP. NOT TO BE DISCLOSED TO OTHERS. REPRODUCTION OR USED FOR ANY OTHER PURPOSE EXCEPT AS AUTHORIZED IN WRITING BY DANIELS MANUFACTURING. MUST BE RETURNED TO DANIELS MANUFACTURING CORP. ON COMPLETION OF ORDER OR PURPOSES FOR WHICH LENT.  
CREATED FROM AN INVENTOR MODEL. CHANGES MUST BE REFLECTED IN THE 3D PART  
DO NOT SCALE DRAWING

MATERIAL	ITEM	PART NO.	QTY.	DESCRIPTION / REMARKS
N/A	DRN. LME CHK'D. MGS	DATE 9/8/1986 DATE 9/23/1986		DANIELS MANUFACTURING CORP. ORLANDO, FLORIDA CAGE 11851
HEAT TREAT N/A	NOTE: THIS DRAWING IS AN OUTLINE DRAWING OF THE RESPECTIVE DMC PART NUMBER INDICATED. ACTUAL DMC PART NUMBER IS CAD PART NUMBER WITHOUT THE "-ENV" SUFFIX		TITLE: CRIMP TOOL M22520/2-01 ENVELOPE DRAWING	
FINISH N/A	WHERE USED:	SIZE C	SCALE 1.75X	CAD P/N AFM8-ENV DWG. NO. AFM8
				SHEET 1 OF 1 REV. 4